

KFC-1681

SERVICE MANUAL

KENWOOD

© 1986-12 PRINTED IN JAPAN
B51-3106-00 (G) 2015

EXTERNAL VIEW

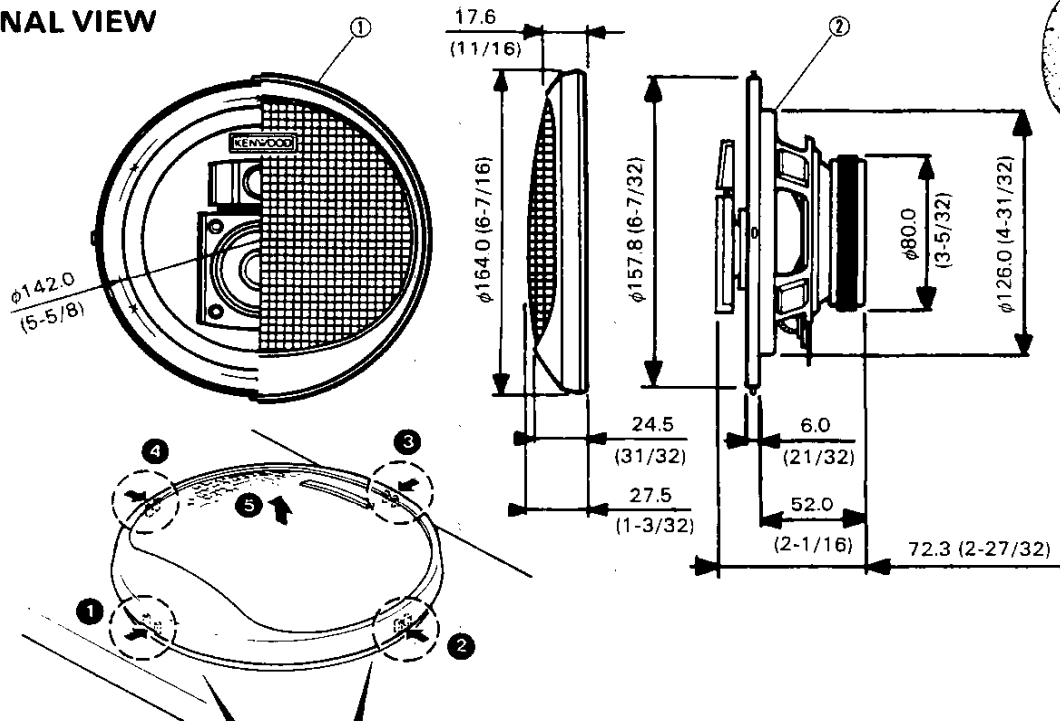

Q.C.
COPY

Unit: mm (inch)

To remove the front grille, pry out the cut off portions ① to ④ with a (-) screwdriver in turn as shown in the left figure.

PARTS LIST

* New Parts

Parts without Parts No. are not supplied.

Les articles non mentionnes dans le Parts No. ne sont pas fournis.

Teile ohne Parts No. werden nicht geliefert.

SPECIFICATIONS

Speakers

- Woofers: 190g (6.7 oz) Magnet
16cm (6") Poly cone, Ribbon coil
- Mid-Range: 50mm (2") cone
- Tweeter: Horn-loaded disc type
- Peak power: 110 watts
- Sensitivity: 90 dB/w at 1m
- Impedance: 4 ohms
- Insulated cable: 4.5m (14.7ft) 2 pcs
- Weight per speaker with grille: 850 g (1 lb 14 oz)

Ref.No.	New Parts	Parts No.	Description	Destination
①		B06-0254-08	FRONT GRILLE	E
①		B06-0255-08	FRONT GRILLE	T
		E30-1181-08	SPEAKER CORD SET	
		N99-1044-08	SCREW SET	
②	*	T15-0088-08	SPEAKER	E
②	*	T15-0092-08	SPEAKER	T